



LUNA2000-(107-241) Series Commercial and Industrial Hybrid Cooling Grid Forming ESS Fixture

Quick Guide

EN

ZH



EN Before installing the equipment, read the user manual carefully to get familiar with product information and safety precautions. The product warranty does not cover equipment damage caused by failure to follow the storage, transportation, installation, and usage guidelines specified in this document and the user manual. Scan the QR code on the cover of this document to view the user manual and safety precautions. The information in this document is subject to change without notice. Every effort has been made in the preparation of this document to ensure accuracy of the contents, but all statements, information, and recommendations in this document do not constitute a warranty of any kind, express or implied.

ZH 安装设备前请详细阅读用户手册，了解产品信息及安全注意事项。未按照本文档与用户手册的内容存储、搬运、安装和使用设备而导致设备损坏，不在设备质保范围内。您可以扫描本文封面处的二维码，查阅用户手册和安全注意事项等信息。由于产品版本升级或其他原因，本文档内容会不定期进行更新。除非另有约定，本文档仅作为使用指导，文档中的所有陈述、信息和建议不构成任何明示或暗示的担保。

EN After using the fixture, properly store it in the toolbox and secure it in its original position.

ZH 工装使用完毕需装到工具箱中保存，按照初始状态固定。

EN If the hoisting point of the battery pack is deformed or bulges due to jolt during hoisting, use a rubber mallet to adjust it to ensure that the battery pack can be properly pushed into the cabinet.

ZH 请使用本公司设计的吊装工装，若选用非本公司吊装工装，存在产品变形或脱钩等严重风险。如果吊装过程中颠簸，导致电池包吊装接口变形凸起，需通过橡胶锤矫形，确保不影响电池包推入机柜。

1

EN Introduction to the Fixture

ZH 工装介绍

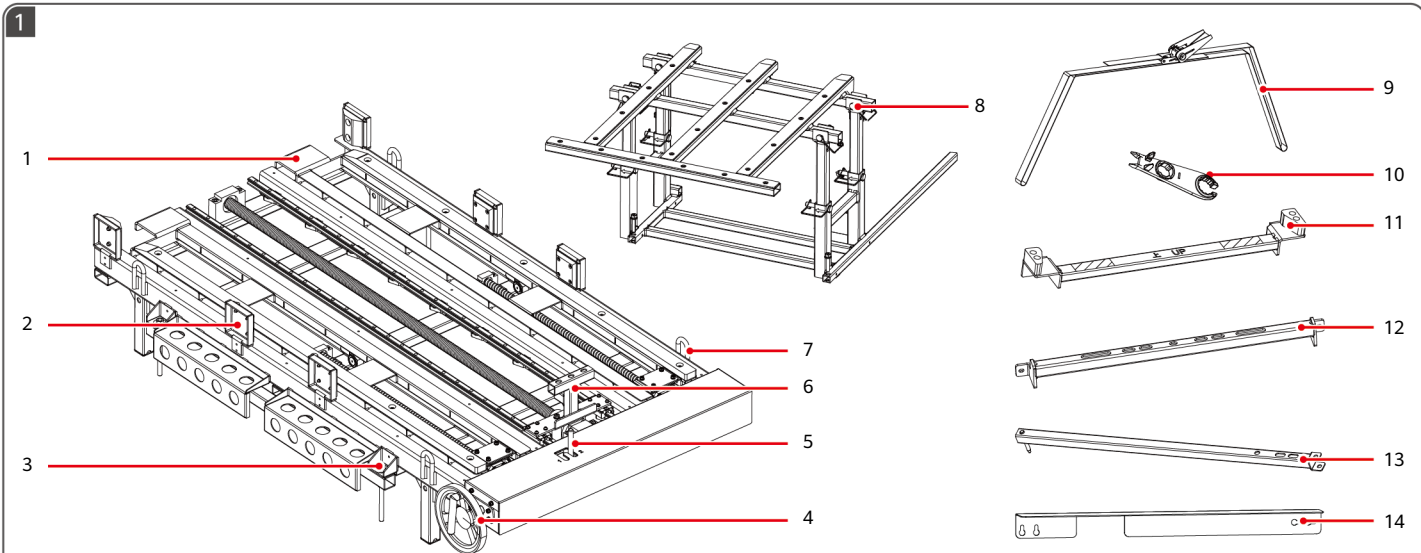

- | | | | | |
|-----------|------------------------------------|-------------------------------|------------------|--------------|
| EN | 1. Drawer handle | 8. PCS fixture | ZH 1.抽屉抓手 | 8.PCS/DCDC工装 |
| | 2. Distance block | 9. Binding strap | 2.限位块 | 9.绑扎绳 |
| | 3. Long bolt | 10. PV terminal removal tool | 3.固定长螺杆 | 10.均衡端子拆卸工具 |
| | 4. Handwheel | 11. Cabinet connecting rod | 4.手轮 | 11.机柜连接杆 |
| | 5. Shifter | 12. Battery connecting rod | 5.档位杆 | 12.电池连接杆 |
| | 6. Battery connecting rod retainer | 13. Extension arm | 6.电池连接杆传动座 | 13.延长臂 |
| | 7. Fixture lifting lug | 14. Panel maintenance fixture | 7.工装吊环 | 14.面板维护工装 |

2

EN Taking Out the Fixture

ZH 取出工装

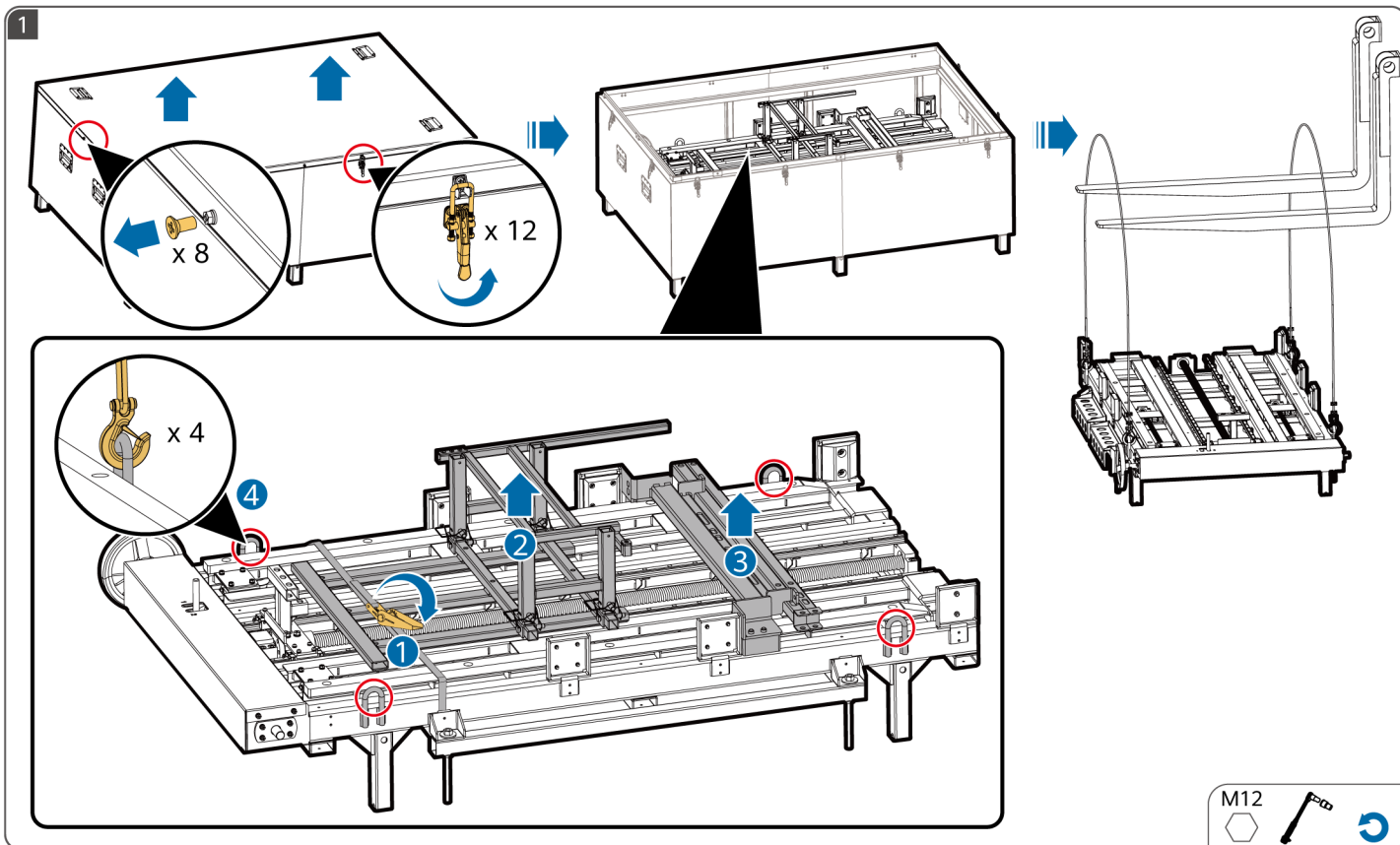

- 1 EN Remove the binding straps from the fixture.
- 2 EN Take out the PCS fixture and place it on the ground.
- 3 EN Take out the cabinet connecting rod and battery connecting rod.
- 4 EN Hook the lifting lug of the battery pack fixture, and use the forklift to lift the battery pack fixture and place it on the ground.

- 1 ZH 拆除工装上的绑扎带。
- 2 ZH 用手取出PCS工装并放置地面。
- 3 ZH 用手取出机柜连接杆和电池连接杆。
- 4 ZH 吊钩勾住PACK工装吊环，用叉车吊出PACK工装放置地面。

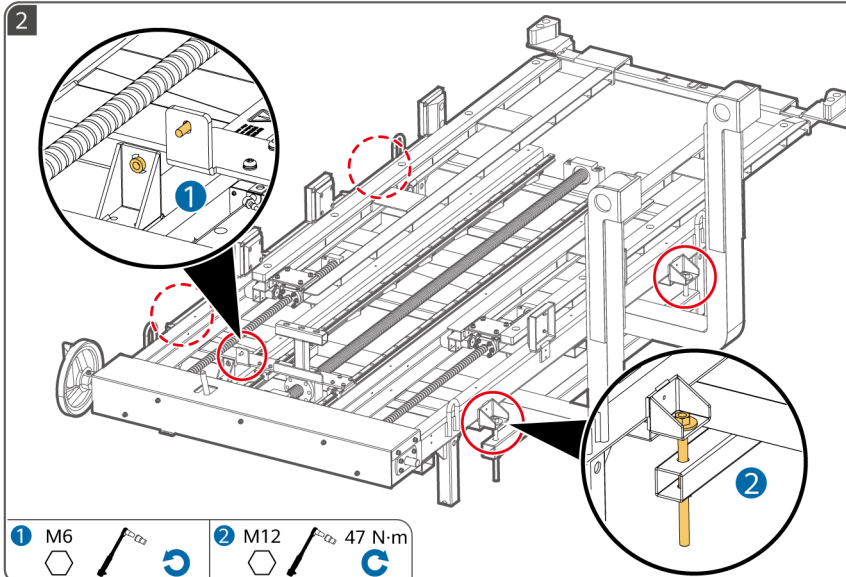

EN Insert the forklift tynes into the pack fixture, remove the M6 screws in 1, adjust the tightness of the long bolt in 2, and secure the pack fixture to the forklift.

ZH 将叉车插入PACK工装，拆除1的M6固定螺钉，调整2的固定长螺杆松紧度，将PACK工装固定在叉车上。

3

EN Replacing a Battery Pack

ZH 更换电池包

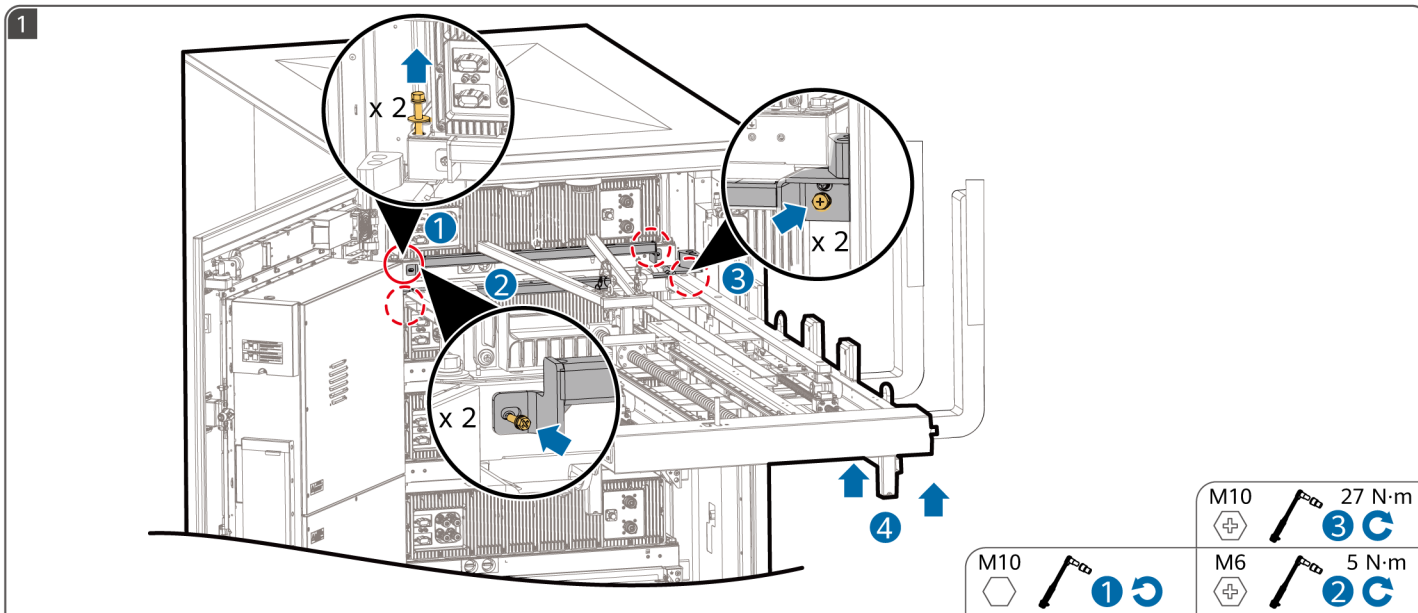

- 1** **EN** Remove the screws that secure the battery pack to the cabinet.
- 2** **EN** Install the battery connecting rod.
- 3** **EN** Install the cabinet connecting rod. Ensure that the side with the silkscreen faces upward.
- 4** **EN** Use the forklift to lift the battery pack fixture slightly higher than the cabinet connecting rod. Adjust the forklift until the fixture is parallel with the cabinet.

- 1** **ZH** 拆除电池包固定在机柜上的螺钉。
- 2** **ZH** 安装电池连接杆。
- 3** **ZH** 安装机柜连接杆，有丝印标识为上方。
- 4** **ZH** 叉车将电池包工装抬升至略高于机柜连接杆，调整叉车使工装与机柜平行。

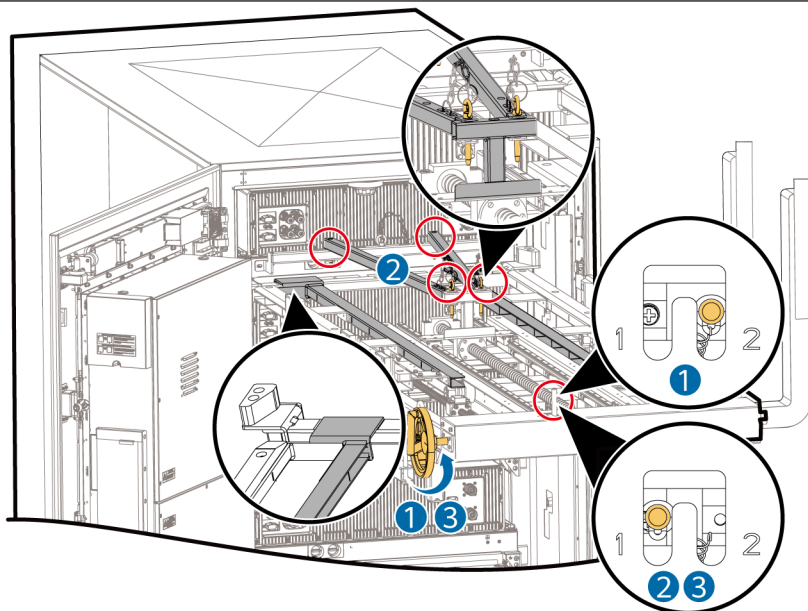

- 1 **EN** Switch to position 2, rotate the handwheel counterclockwise, push the drawer handle to the top of the cabinet connecting rod, adjust the left and right tynes of the forklift to align the handle with the mark on the cabinet connecting rod, and lower the tynes of the forklift until the drawer handle comes in contact with the marked position on the cabinet connecting rod.
- 2 **EN** Switch to position 1. Place the extension arm on the fixture, secure one end of the extension arm to the cabinet connecting rod using the pin, rotate the handwheel, align the hole on the other end of the extension arm with the hole on the battery connecting rod retainer, and insert the pin to secure the extension arm.
- 3 **EN** Keep the position at 1 and rotate the handwheel counterclockwise to pull out the battery pack to be replaced.

- 1 **ZH** 档位调至2档，逆时针旋转手轮，推动抽屉抓手至机柜连接杆正上方，调整叉车左右位置，使抓手与机柜连接杆标识对齐，然后降低叉车臂高度，将抽屉抓手搭接在机柜连接杆标识位置。
- 2 **ZH** 档位调至1档，将延伸臂放在工装上，一端用插销固定在机柜连接杆上，旋转手轮，将延伸臂另一端孔位与电池连接杆传动座孔位对齐，插入插销固定延伸臂。
- 3 **ZH** 保持档位在1档状态，逆时针旋转手轮，拉出待更换电池包。

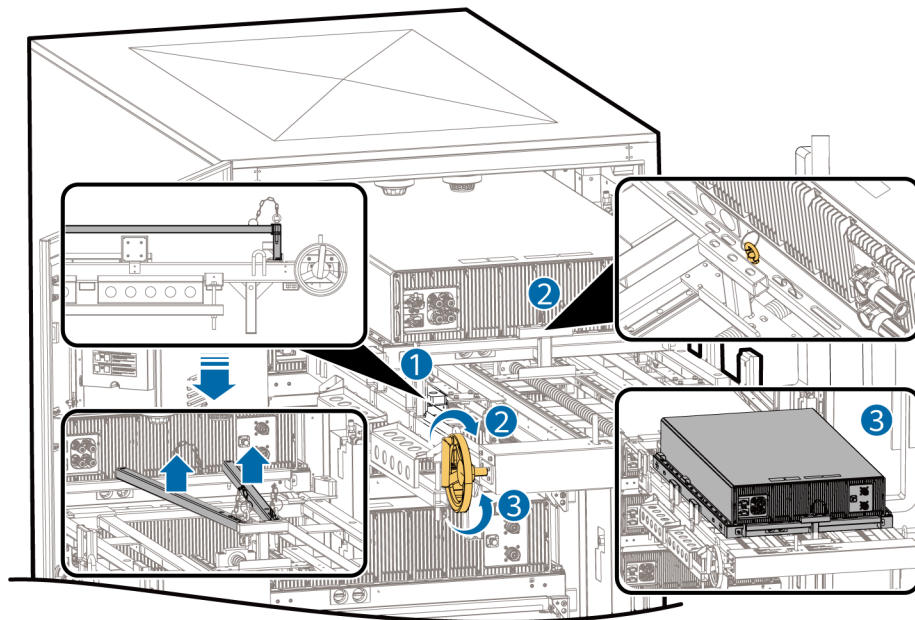

- 1 **EN** Pull the battery connecting rod retainer near the initial position, and then take out the extension arm.
- 2 **EN** Rotate the handwheel clockwise, align the hole on the battery connecting rod retainer with the hole on the battery connecting rod, and insert the pin.
- 3 **EN** Rotate the handwheel counterclockwise to pull the battery pack out of the ESS.

- 1 **ZH** 将电池连接杆传动座推至初始位置附近，取出延伸臂。
- 2 **ZH** 顺时针旋转手轮，调整电池连接杆传动座孔位与电池连接杆孔位对齐，用插销固定。
- 3 **ZH** 逆时针旋转手轮，将电池包完全拉出储能柜。

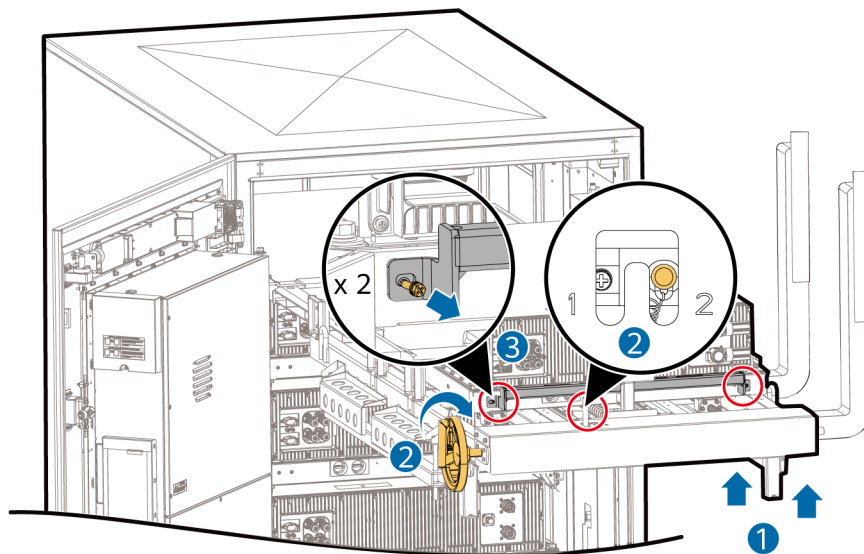

- 1 **EN** Use the forklift to lift the fixture slowly until the drawer handle is slightly higher than the cabinet connecting rod.
- 2 **EN** Switch to position 2. Rotate the handwheel clockwise until the drawer handle is fully retracted. Move the battery pack to a safe place and place it on the ground.
- 3 **EN** Remove the battery connecting rod.

- 1 **ZH** 叉车向上缓慢抬起工装，使抽屉抓手略高于机柜连接杆。
- 2 **ZH** 调整档位至2档，顺时针旋转手轮，直至抽屉抓手完全收回，将电池包转移至安全地带，放置地面上。
- 3 **ZH** 拆除电池连接杆。

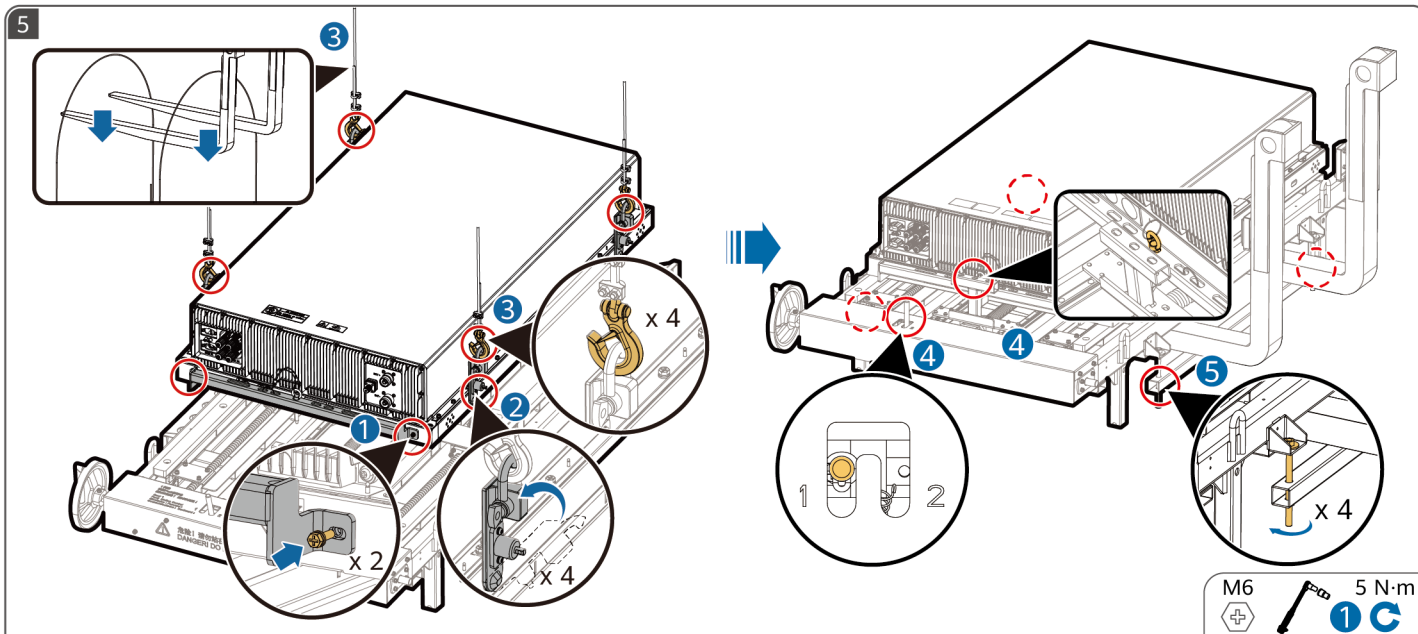

- 1 EN** Take out the battery connecting rod and secure it to the new battery pack.
- 2 EN** Install the battery pack hoisting kit.
- 3 EN** Install the lifting rope, hook the hoisting kit using the hook, lift the battery pack using the forklift, and place the battery pack in the middle of the fixture.
- 4 EN** Switch to position 1, rotate the handwheel, adjust the battery connecting rod retainer and battery connecting rod to overlap with the pin hole, and insert the pin.
- 5 EN** Insert the forklift tynes into the fixture, adjust the tightness of the long bolt, and secure the battery pack fixture to the forklift.

- 1 ZH** 取出电池连接杆，并将其固定在新电池包上。
- 2 ZH** 安装电池包吊装组件。
- 3 ZH** 安装吊绳，将吊钩勾住电池包，然后叉车吊出电池包，居中放置工装上。
- 4 ZH** 将档位调至1档，旋转手轮，将电池连接杆传动座与电池连接杆调整至插销孔重合位置，并插入插销。
- 5 ZH** 叉车插入工装，调整长螺杆松紧度，将电池包工装固定在叉车上。

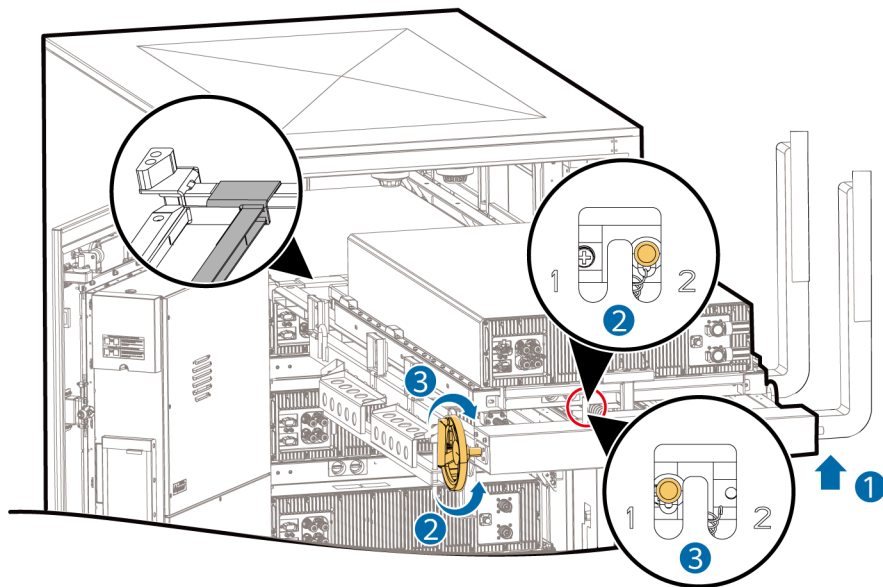

- 1 **EN** Use the forklift to lift the battery pack fixture slightly higher than the cabinet connecting rod. Adjust the forklift until the fixture is parallel with the cabinet.
- 2 **EN** Switch to position 2, rotate the handwheel counterclockwise, push the drawer handle to the top of the cabinet connecting rod, adjust the left and right tynes of the forklift to align the handle with the mark on the cabinet connecting rod, and lower the tynes of the forklift until the drawer handle comes in contact with the marked position on the cabinet connecting rod.
- 3 **EN** Switch to position 1, rotate the handwheel clockwise, and push a part of the battery pack into the cabinet.

- 1 **ZH** 叉车将电池包工装抬升至略高于机柜连接杆，调整叉车使工装与机柜平行。
- 2 **ZH** 档位调至2档，逆时针旋转手轮，推动抽屉抓手至机柜连接杆正上方，调整叉车左右位置，使抓手与机柜连接杆标识对齐，然后降低叉车臂高度，将抽屉抓手搭接在机柜连接杆标识位置。
- 3 **ZH** 将档位调至1档，顺时针旋转手轮，将电池包部分推入机柜。

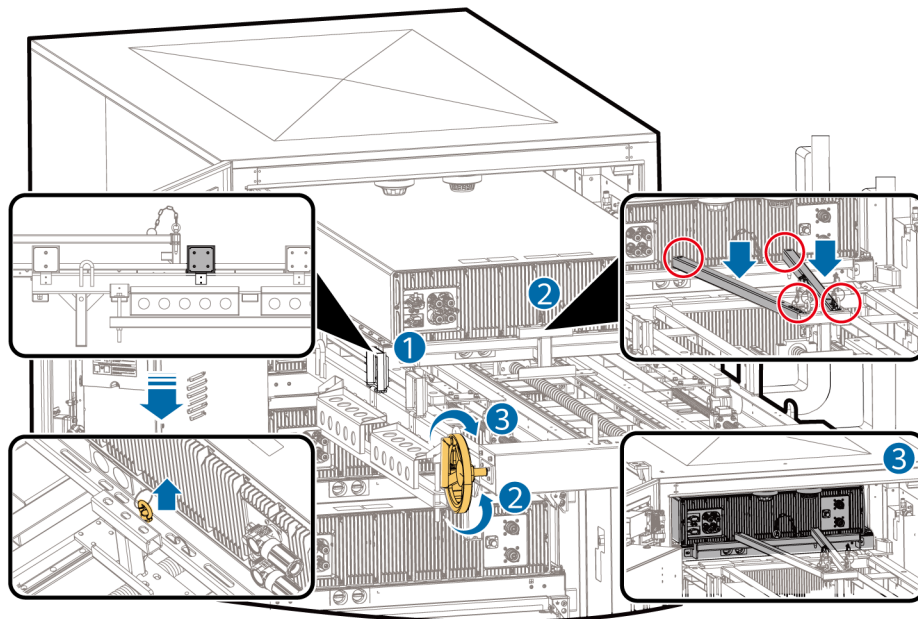

- 1 EN Push the battery connecting rod retainer until it exceeds the distance block, as shown in the figure. Pull out the battery connecting rod pin.
- 2 EN Place the extension arm on the fixture, secure one end of the extension arm to the cabinet connecting rod using the pin, rotate the handwheel, align the hole on the other end of the extension arm with the hole on the battery connecting rod retainer, and insert the pin to secure the extension arm.
- 3 EN Rotate the handwheel clockwise to push the battery pack completely into the ESS.

- 1 ZH 将电池连接杆传动座推至如图所示超过限位块附近后拔出电池连接杆插销。
- 2 ZH 将延伸臂放在工装上，一端用插销固定在机柜连接杆上，旋转手轮，调整延伸臂另一端孔位与电池连接杆传动座孔位对齐，插入插销固定延伸臂。
- 3 ZH 顺时针旋转手轮，将电池包完全推入储能柜。

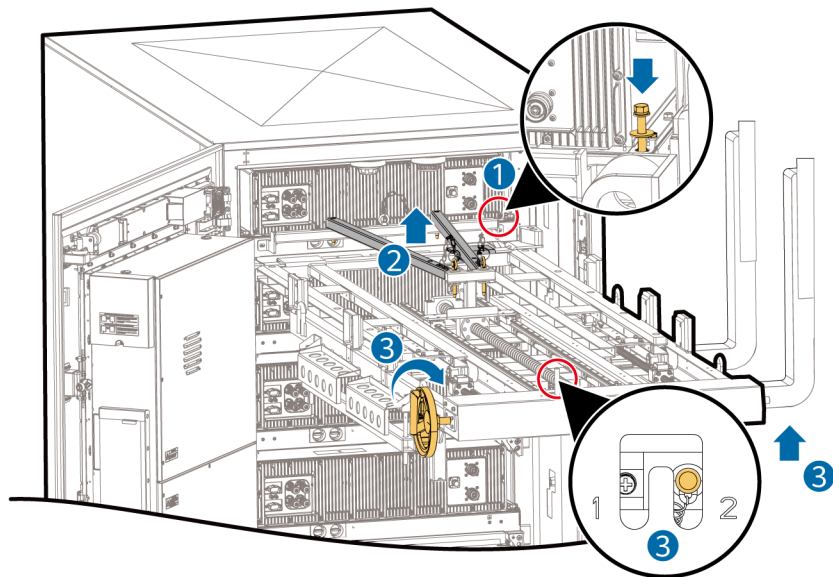

M10



47 N·m



- 1 EN When the front end of the battery pack is aligned with the guide rail of the cabinet and the gap between the fixture and the guide rail of the cabinet is exposed, partially tighten the screws on the battery pack on the forklift side.
- 2 EN Pull out the pin and take out the extension arm.
- 3 EN Use the forklift to lift the fixture slowly until the drawer handle is slightly higher than the cabinet connecting rod. Ensure that the drawer handle does not contact the battery connecting rod. Switch to position 2, rotate the handwheel clockwise until the drawer handle is fully retracted, and drive the forklift to move the fixture to a safe place.

- 1 ZH 当电池包前端与电池包机柜导轨齐平，露出工装与机柜导轨间的缝隙时，手动预紧叉车一侧电池包固定螺钉。
- 2 ZH 拔出插销，取出延伸臂。
- 3 ZH 叉车向上缓慢抬起工装，使抽屜抓手略高于机柜连接杆，注意不要与电池连接杆干涉。将档位归于2档，顺时针旋转手轮，直至抽屜抓手完全收回，驾驶叉车将工装转移至安全地带。

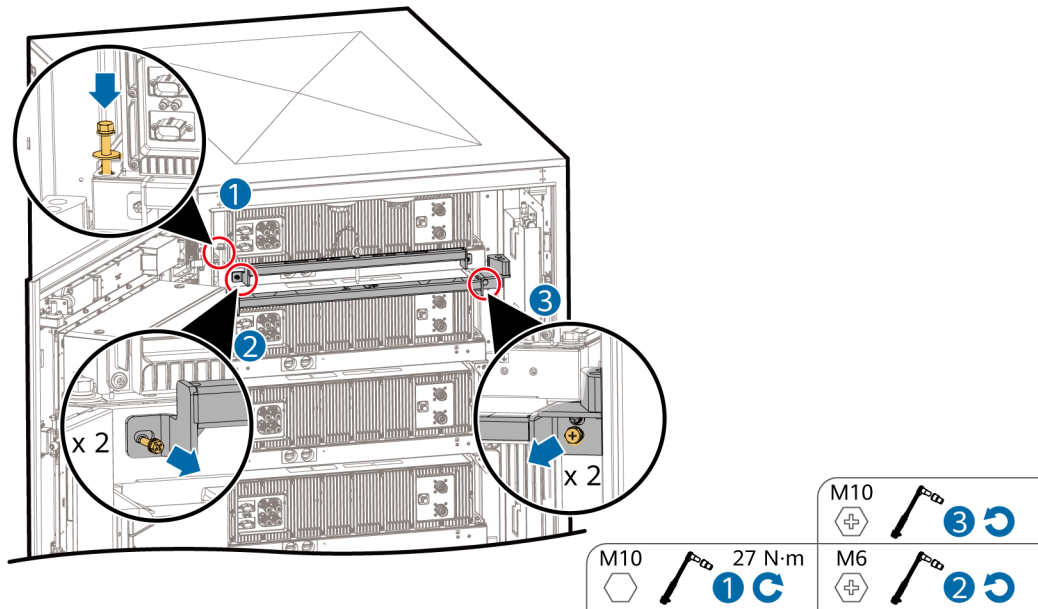

- 1 **EN** Install the battery pack screws on the LTMS side, and use a socket wrench to tighten the screws on both sides.
- 2 **EN** Remove the cabinet connecting rod.
- 3 **EN** Remove the battery connecting rod.

- 1 **ZH** 安装液冷机组一侧电池包固定螺钉，并用套筒紧固两侧螺钉。
- 2 **ZH** 拆除机柜连接杆。
- 3 **ZH** 拆除电池连接杆。

EN After using the fixture, properly store it in the toolbox and secure it in its original position.

ZH 工装使用完毕需装到工具箱中保存，按照初始状态固定

4

EN Replacing a PCS/DCDC (The following steps use PCS as an example.)

ZH 更换PCS/DCDC (以下步骤均以PCS为例)

1

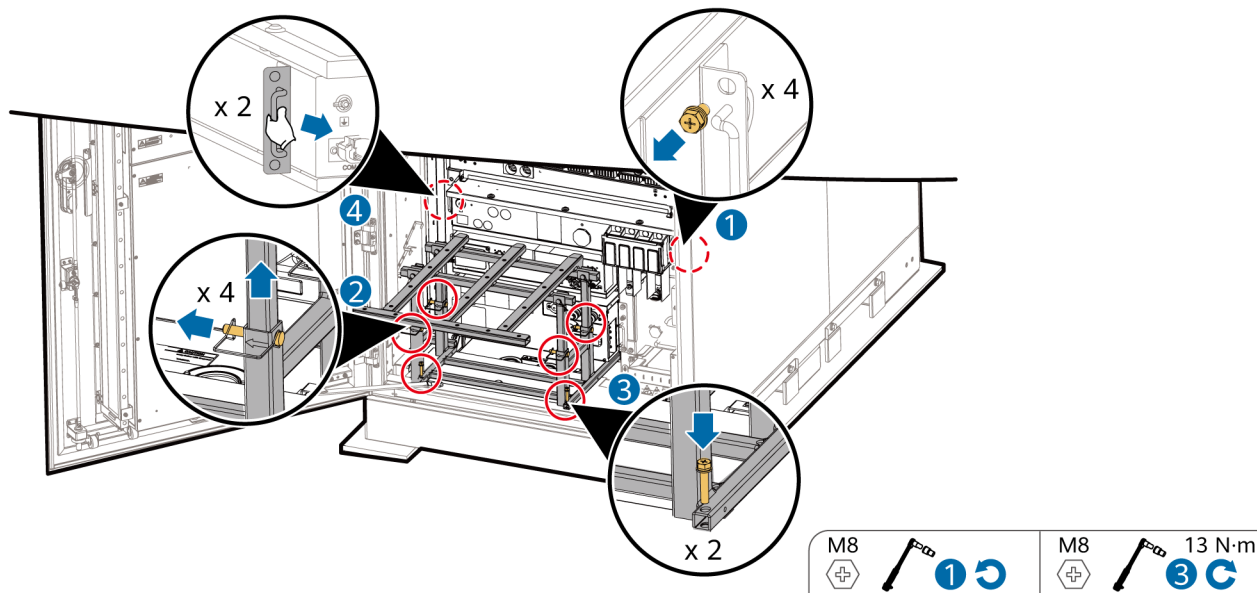

1 EN Remove the screws that secure the PCS/DCDC to the ESS.

1 ZH 拆除PCS/DCDC固定在机柜上的螺钉。

2 EN Remove the pins, raise the fixture outside the ESS, place the fixture into the ESS, and insert the pins in the positions, as shown in the figure. (Perform this operation only when the PCS is replaced)

2 ZH 按图示将插销拔出，在机柜外把工装升高后再放入机柜，插好插销，并放置在图示位置。（若更换DCDC则没有该步骤）

3 EN Secure the fixture to the ESS.

3 ZH 将工装固定在储能柜。

4 EN Hold the handles on both sides of the faulty PCS/DCDC and pull the PCS/DCDC to the fixture.

4 ZH 用手抓住PCS/DCDC两边的把手，将PCS/DCDC拉出至工装上。

2

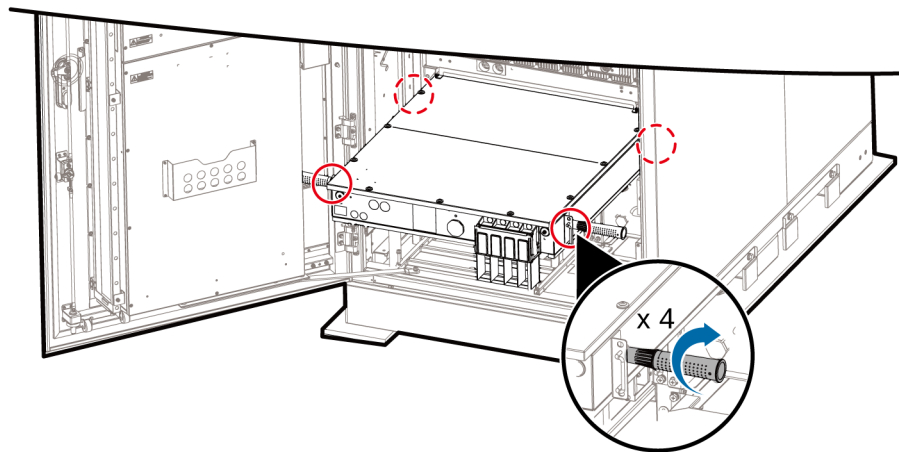

EN Install the lifting handles and lift the PCS/DCDC to a safe ground.

ZH 安装抬手棒，将PCS/DCDC抬至安全地面放置。

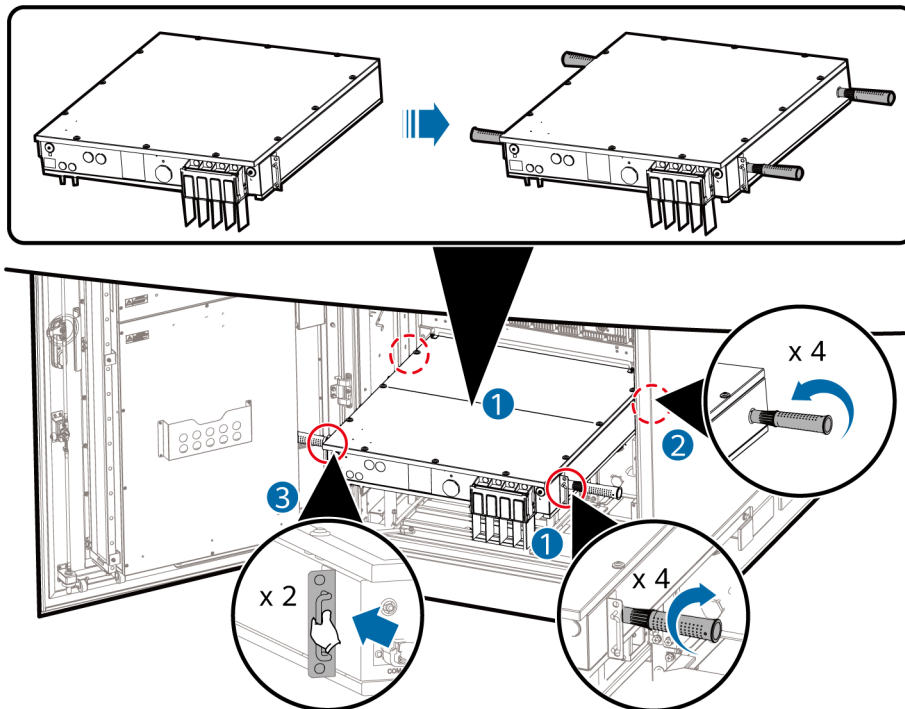

- 1 EN Take out a new PCS/DCDC and install the lifting handles.
- 2 EN One person stands on each side of the PCS/DCDC to lift the PCS/DCDC onto the fixture to avoid falling, and then remove the lifting handles.
- 3 EN Hold the handles on both sides and slowly push the PCS/DCDC into the ESS.

- 1 ZH 取出新的PCS/DCDC，安装抬手棒。
- 2 ZH 一人一侧将PCS/DCDC抬至PCS/DCDC工装上，避免跌落，然后拆除抬手棒。
- 3 ZH 抓住两侧把手，将PCS/DCDC缓慢推入储能柜中。

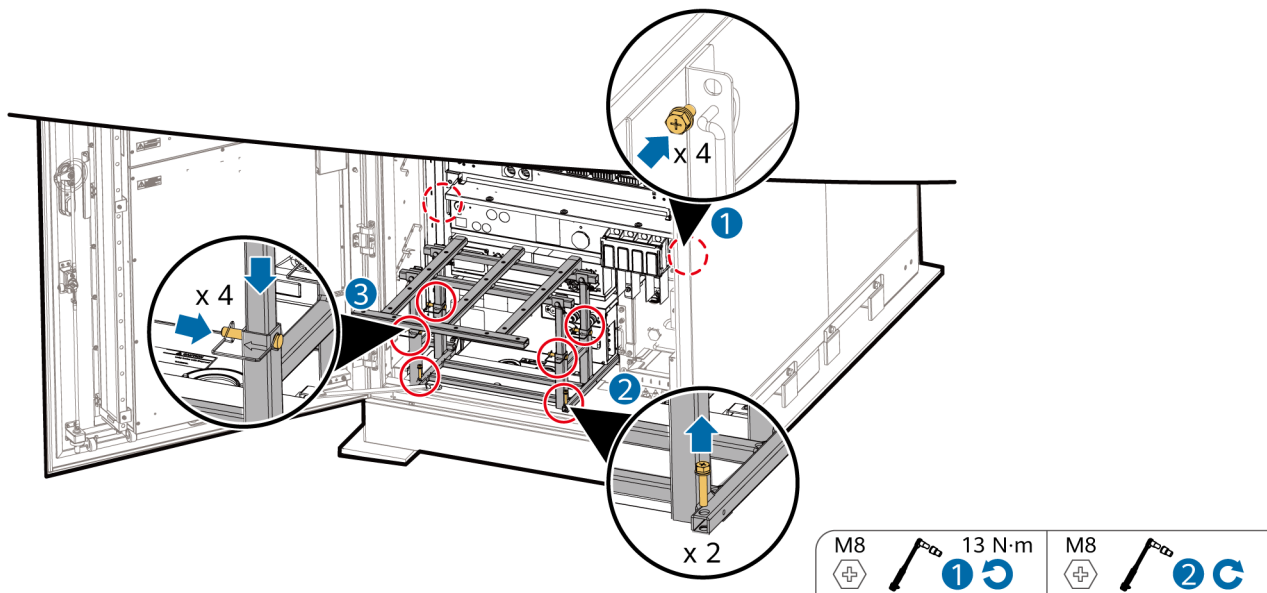

- 1 **EN** Push the new PCS/DCDC completely into the ESS and tighten the screws.
- 2 **EN** Remove the screws from the PCS/DCDC fixture, remove the fixture, and close the ESS door.
- 3 **EN** After taking out the PCS/DCDC fixture, remove the pins, lower the fixture, and insert the pins. (Perform this operation only when the PCS is replaced)

- 1 **ZH** 将PCS/DCDC完全推进储能柜，安装固定螺丝。
- 2 **ZH** 拧出PCS/DCDC工装的固定螺丝，将工装取走后，关闭柜门。
- 3 **ZH** 取出PCS/DCDC工装后，按图示将插销拔出，把工装降低归位后再插好插销。（仅更换PCS需要执行该操作）

EN After using the fixture, properly store it in the toolbox and secure it in its original position.

ZH 工装使用完毕需装到工具箱中保存，按照初始状态固定。



Huawei Digital Power Technologies Co., Ltd.

Huawei Digital Power Antuoshan Headquarters

Futian, Shenzhen 518043

People's Republic of China

digitalpower.huawei.com